

MOTOR LENGTH

GEAR RATIO	L1	L2
4.7	7.4	24.9
22	9.6	27.1
105	11.8	29.3
494	14.1	31.6

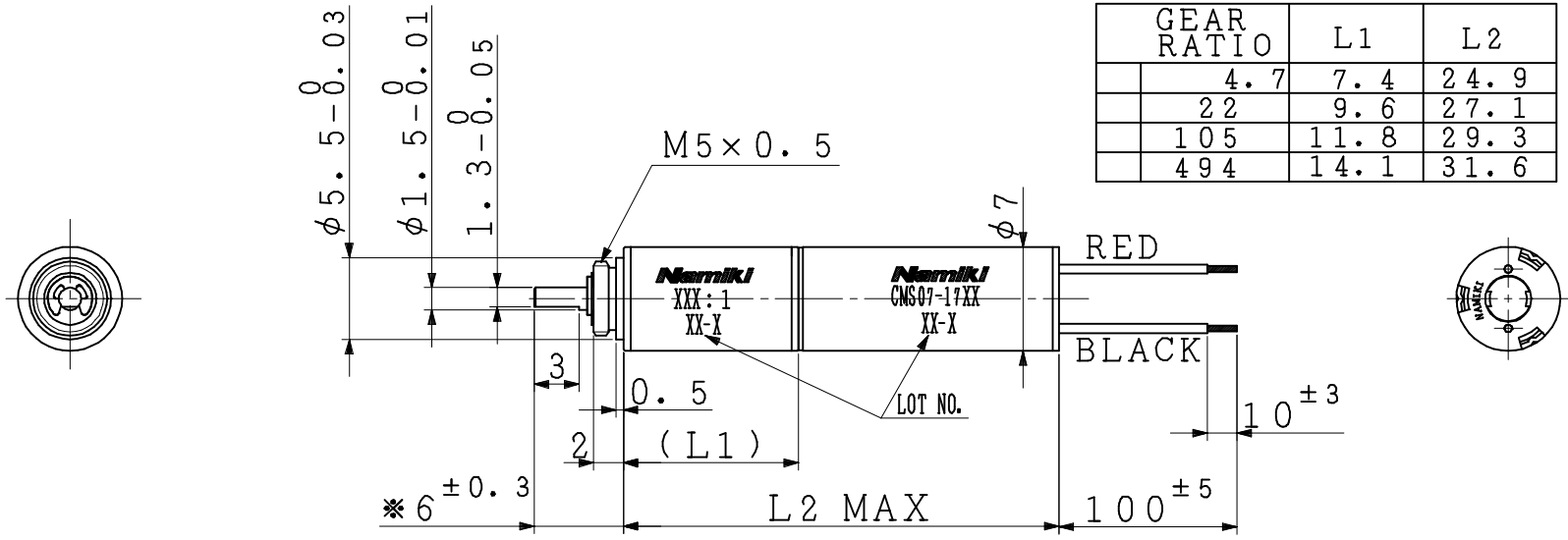

NOTE 1) MARKED(*) IS OUTPUT SHAFT LENGTH MEASURED WHEN IT IS PUSHED TO MOTOR SIDE.
 *印寸法は出力軸をモータ側に押しつけた時の値を示す。

2) LOT NO.
 EXAMPLE) JANUARY, 2018
 「18-A」
 JANUARY: A, FEBRUARY: B... DECEMBER: L
 1月: A、2月: B... 12月: L
 「-」 : MADE IN THAILAND
 「-」有り : 海外工場生産
 「-」NONE : MADE IN JAPAN
 「-」無し : 国内工場生産
 THE END TWO DIGIT OF CHRISTIAN YEAR
 西暦年数末尾数字2桁

3) THE LEAD WIRE IS AWG30 UL3302.
 リード線はAWG30 UL3302を使用する。
 4) OUTSIDE DIAMETER IS NOT APPLIED TO THE CAULKING.
 外径寸法公差はカシメ部を除く。

TOLERANCE				△	×				
DIMENSION (±)			ANGLE	△	×				
	0	1	2	3					
L ≤ 6	0.05	0.1	0.1	0.2	±1°				
6 < L ≤ 30	0.1	0.1	0.2	0.5					
30 < L ≤ 120	0.15	0.2	0.3	0.8					
120 < L	0.2	0.3	0.5	1.2					
MATERIAL	FINISH	QTY.	SCALE	2/1	TYPE	CMS07-17 P			
			UNIT	1/1mm	TITLE	OUTLINE DRAWING			
APPD.	CHK.	DSGN.	DRW.	DWG.NO.					
		Demachi	Demachi	REF.NO.					
		15-Jan-18	15-Jan-18	CHK.NO.	REMARK	Rev. 00			